

# PRODUCT SPECIFICATION

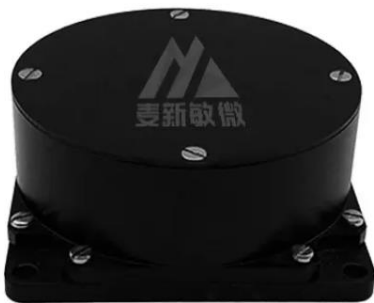

**PRODUCT TYPE: G-F70HA**

**PRODUCT DESCRIPTION: MEDIUM AND HIGH PRECISION**

**FIBER OPTIC GYROSCOPE**



## CONTACT US

MICRO-MAGIC INC

**Email:** [sales@memsmag.com](mailto:sales@memsmag.com)

**Whatsapp:** +8618151836753

**Tel/wechat:** +8618621961329

**Website:** [www.memsmag.com](http://www.memsmag.com)

## 1 Introduction

As a new type of all-solid state gyro, fiber optic gyroscope has the advantages of fast start, wide measurement range and high reliability. G-F70HA uniaxial medium and high precision fiber optic gyroscope can be applied to the application requirements of high precision inertial navigation system, such as land positioning orientation, vehicle north finding instrument, airborne navigation posture and marine gyro.

### 1.1 Applied range

The specification is only applicable to G-F70HA type products, including performance indicators, technical conditions, external dimensions and installation and use. Among them, the technical conditions include the environmental range, electrical performance and physical characteristics of the product.

### 1.2 Main parameter

#### 1.2.1 Main performance index of the fiber optic gyroscope:

Table 1. Main performance indicators of the products

<b>Zero bias stability</b>	$\leq 0.05 \text{ }^\circ/\text{hr} (1\sigma, 10s)$	2h continuous testing, 10s smooth results
<b>Stabilization time</b>	$< 100 \text{ s}$	
<b>Zero bias repeatability</b>	$\leq 0.05 \text{ }^\circ/\text{hr} (1\sigma)$	6 test data calculation results
<b>Random walk coefficient</b>	$\leq 0.005 \text{ }^\circ/\sqrt{\text{hr}}$	
<b>The Scale factor of Nonlinearity</b>	$\leq 20 \text{ ppm} (1\sigma)$	normal atmospheric temperature
<b>The Scale factor of Repeatability</b>	$\leq 20 \text{ ppm} (1\sigma)$	normal atmospheric temperature
<b>Full-temperature scale factor repeatability</b>	$\leq 200 \text{ ppm} (1\sigma)$	$-40^\circ\text{C} \sim +60^\circ\text{C}$
<b>Dynamic range</b>	$\pm 400^\circ/\text{s}$	

<b>Magnetic field sensitivity</b>	$\leq 0.02 \text{ }^\circ/\text{hr}/\text{Gs}$	
<b>Working temperature</b>	$-40^\circ\text{C} \sim +70^\circ\text{C}$	
<b>Storage temperature</b>	$-50^\circ\text{C} \sim +70^\circ\text{C}$	
<b>Vibration conditions</b>	$4.2\text{g}, 20\text{Hz} \sim 2000\text{Hz}$	Sweep frequency vibration has no resonance

## 1.2.2 Mechanical test

### 1.2.2.1 The sinusoidal scan vibrations

The gyro is fixed on the vibration table through the tooling according to the vibration direction, and the gyroscope conducts sinusoidal scanning in three directions, corresponding to the X axis, Y axis and Z axis respectively. Vibration steps; vibration table add magnetic, power the gyroscope, preheating for a certain time (gyro start time), test the gyroscope output value, about 5min; sinusoidal vibration. Vibration conditions: 20Hz-2000Hz, scan time of 5min, amplitude of 4.2g. During the vibration process, record the gyroscope output.

### Random vibration

Vibration frequency: 20Hz~2000Hz

Vibration time: each axis is 5min respectively

Vibration direction: X, Y, and Z axis

Vibration spectrum diagram: see attached

Figure 1

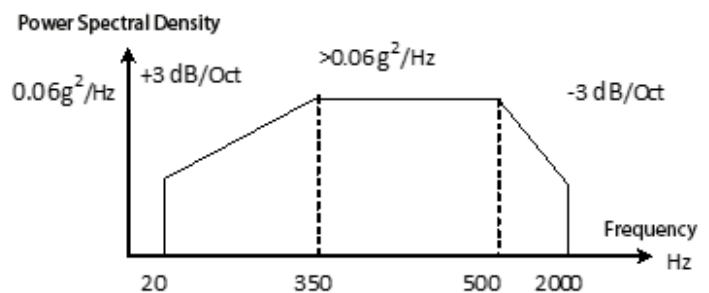

Figure 1 Vibration spectrogram

Index requirements:

Fiber gyro scan with sinusoidal sweep from 20 Hz ~ 2000 Hz range without resonance;

Random vibration: the absolute value of the zero bias in vibration and the zero bias is required to be less than  $0.10^\circ / \text{h}$ .

### 1.2.2.2 Mechanical impact is as specified in Table 2

Table 2. Impact test conditions

<b>Peak acceleration (g)</b>	30
<b>Duration (ms)</b>	10
<b>Impact times</b>	Each direction was 3 times
<b>Wave form</b>	half-sin wave
<b>Direction</b>	X、Y、Z
	Note: The interval between the two shocks is not less than 1.5s

During the impact process, the product is in the power state, complete the mechanical impact product, should be able to work normally, the change value of zero before and after the impact is less than  $0.05^\circ / h$ .

## 2. Communication protocol

### 2.1 RS-422 mode (bi-directional)

- a) Two-way serial port communication complies with RS-422 interface standard;
- b) External trigger signals, adaptive 10 HZ ~ 4000 HZ;
- c) After the gyro detects the descent of the external trigger signal, start to send data outward;
- d) The effective gyro effective data is 32 bits;
- e) The temperature valid data is 14 bits;
- f) The data transmission wave rate is 460.8kbps;
- g) Data format:
  - a) Data transmission format: each frame data is 11 bits, including: the first bit is the start bit (0), the second to ninth bit is the data bit, the tenth bit is the parity bit, and the 11th bit is the stop bit;
  - b) Verification method: even calibration;
  - c) effective data of gyro is 32 (highest is symbol bit, 0 is "+", 1 is "-"), temperature effective data bit is 14 (highest is symbol bit, 0 is "+", 1 is "-");
  - d) Packet format: each transmission includes 10 bytes, Byte 1 is the frame head (80H); Second byte is the first byte of gyro data (low byte); The third byte is the second byte of

the gyro data; The fourth byte is the third byte of the gyro data; The fifth byte is the fourth byte of the gyro data; The sixth byte is the fifth byte of the gyro data (high byte); The 7th byte is the check bit, The XOR value of the first 5 bytes (gyro data) in the data packet; byte 8 is low byte of temperature data; The 9th byte is the high byte of the temperature data; The 10th bit is the check bit, The XOR value of the first 8 bytes (gyro data) in the data packet;

e) Method of data storage.

	high-order				low-order			
Bytes 1 (frame head):	1	0	0	0	0	0	0	0
Bytes 2:	0	D6	D5	D4	D3	D2	D1	D0
Bytes 3:	0	D13	D12	D11	D10	D9	D8	D7
Bytes 4:	0	D20	D19	D18	D17	D16	D15	D14
Bytes 5:	0	D27	D26	D25	D24	D23	D22	D21
Bytes 6:	0	0	0	0	D31	D30	D29	D28
Bytes 7:	0	X	X	X	X	X	X	X
Bytes 8:	0	T6	T5	T4	T3	T2	T1	T0
Bytes 9:	0	T13	T12	T11	T10	T9	T8	T7
Bytes 10:	0	X	X	X	X	X	X	X

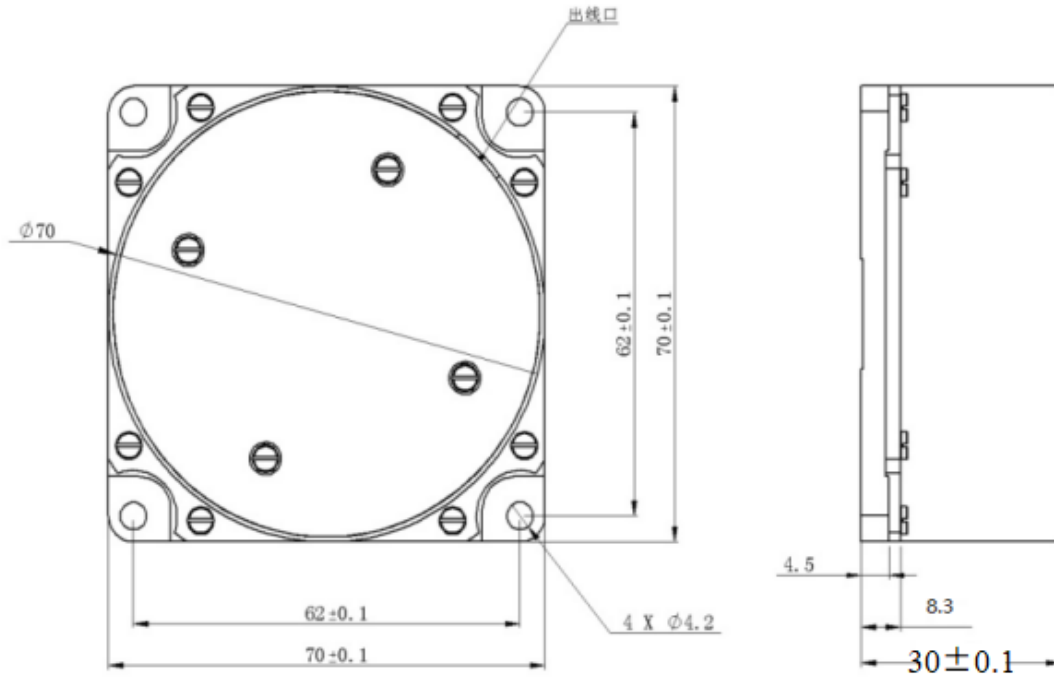

**Graph 2 Outline dimensions of G-F70HA**

J30-15 ZK socket, the connector is defined in Table 3.

Table 3. Electrical characteristics of the gyro output socket

Connect the point number	Connection definition	Tab	Color
1	Serial port T+	TX+	Yellow
2	Serial port T-	TX-	Orange
3	Serial port R+	RX+	Blue
4	Serial port R-	RX-	Green
5、13	Power source +5V	+5V	Red
6、7	Power ground	GND	Black